

INSTRUCTION MANUAL

AIR ABRASIVE DISC ANGLE SANDER PNEUMATIC FILE

Please read this manual carefully before you attempt to use your tool so that you may use it properly and safely.

MYTON
PROFESSIONAL TOOL

Model MLS-20

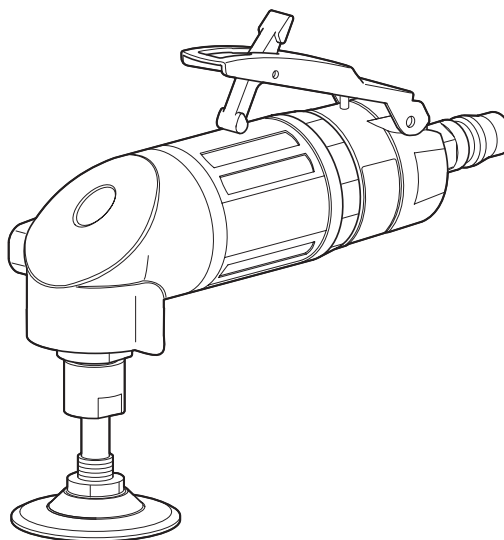

Specifications

Model		MLS-20
Rated Air Pressure	[MPa]	0.6
Air Consumption(No Load)	[m ³ /min]	0.42
Rated Speed(No Load)	[min ⁻¹]	19000
Abrasive Disc Dia.	[mm]	25(1"), 38(1.5"), 50 (2 ")
Chack Size	[mm]	6
Mass(Weight)	[kg]	0.55 (1.21 lb.)
Sound Pressure Level	[dB(A)]	85
Sound Power Level	[dB(A)]	96
Vibration Level	[m/s ²]	≤ 2.5

Due to continuous product development/improvement the specifications and configurations in this document are subject to change without prior notice.



Manufactured by :

NITTO KOHKI CO., LTD.

2-9-4, Nakaikagami, Ohta-ku,
Tokyo 146-8555, Japan

Tel : (03)3755-1111

Fax : (03)3753-8791

E-mail : overseas@nitto-kohki.co.jp

URL : www.nitto-kohki.co.jp

Keep the manual handy – so you can use it whenever necessary.

Original Instructions

Thank you very much for your purchase of this **Nitto Kohki products.**

Before using your tool, please read this manual carefully so that you may use it properly to get the most out of it.

Please keep the manual handy - so you can use it whenever necessary.

- **English** : Please ask your dealer or distributor for instruction manual in local language(s)
- **German** : Bitte fragen Sie Ihren Händler nach eine Betriebsanleitung in Landessprache.
- **French** : S'il vous plait, veuillez demandez á votre fournisseur de manuel instruction en langue locale.
- **Spanish** : Por favor, contacte con su distribuidor para el manual de instrucciones en español.
- **Portuguese** : Por favor pessa ao seo agente ou distribuidor o manual de instrucces ih linguagen local.
- **Italian** : Per Manuale Istruzioni in lingua locale Vi preghiamo di rivolgervi al rivenditore o distributore.
- **Dutch** : Vraag uw handelaar om een nederladstalige gebruiksaanwijzing.
- **Swedish** : Be er lokala Åtreförsäljare eller distributör om manualer på svenska.
- **Danish** : Venligst henvend Dem til den danske distributør for instructions manualer.
- **Polish** : Proszę pytać swojego dealera lub dystrybutora o instrukcje obsługi w języku localnym.
- **中文** : 請向當地供應商或經銷商詢問中文使用說明書

CONTENTS	page
IMPORTANT SAFETY INSTRUCTIONS	2
GENERAL: TOOLS	2
GENERAL: PNEUMATIC TOOLS	3
INSTRUCTIONS FOR THIS TOOL	4
1 USAGE	4
2 CHECK THE CONTENTS OF THE PACKAGE	4
3 PART NAME	4
4 AIR SUPPLY	5
5 OPERATION	5
6 STORAGE	6
7 MAINTENANCE	6
8 ORDERING SERVICE PARTS	6
9 OPTIONAL PARTS	7

PICTOGRAM



Warning: It might be dangerous to operate the tool if the instructions supplied are not followed.



Using this tool improperly could result in serious injury. Read the instruction manual before using.



Always wear suitable eye protection.



Always wear suitable hearing protection.



Always wear respiratory protective equipment.

The following Safety notations are used throughout the manual to highlight safety precautions for the user and for the tool.

WARNING:	Indicates a potentially hazardous situation which, if not avoided by following the instructions given, could result in death or serious injury.
CAUTION:	Indicates a potentially hazardous situation which, if not avoided by following the instructions given, could result in injury or material damage.

Please note, however, that failure to observe safety precautions under the “**Caution**” category could result in a serious occurrence depending on the situation: please observe all safety precautions in the manual.

Caution: Important precautions for tool setup, operation and maintenance.

IMPORTANT SAFETY INSTRUCTIONS

When using the tool, please observe the safety precautions below to prevent possible accident or injury.

GENERAL : TOOLS

WARNING

TO OPERATORS

- **Wear proper clothing for the type of work being done.**
Take care so that clothing, ties, hair, etc. will not become entangled with the moving parts. If items become entangled it will cause the operator to be pulled towards the tool and lead to possible cause of accident or injury.
- **Always wear suitable eye protection.**
Vision correction glasses are not safety glasses. Always wear appropriate safety glasses when doing your job.
- **Always wear suitable hearing protection.**
- **Wear respiratory protective equipment (PPE).**
Wear respiratory protective equipment (PPE) when working in an environment where dust particles are generated in operation.
- **Avoid working posture that is too stressful.**
Always ensure a firm footing and well balanced posture.
- **Do not operate the tool if you are too tired.**
- **Never touch any moving parts of the tool when running.**

ABOUT WORK AREA

- **Keep the work area clean.**
Cluttered work areas (e.g. workbench) invite accidents.
- **Carefully select the work area.**
Do not expose tool to rain.
Do not use tool in a wet or soaked area.
See that the work area is adequately illuminated.
- **Never work near inflammable liquid or in a potentially explosive atmosphere.**
- **Keep children away from the work area.**
Keep children and unauthorized people away from the work area to avoid accident or injury.
- **Some tools generate high noise levels.**
Check to be sure that the use of this tool conforms to all local noise regulations.

BEFORE OPERATION

- **Inspect tool before use.**
Before using, check that screws are securely tightened, that any protective cover or guard is securely in place, other parts are free from damage and that the tool runs as it should.
Check that moving parts are properly adjusted for positioning and tightened, that parts are free from damage and properly mounted, and that all other parts are in good condition for normal operation.
Should you find any damage to the protective cover or other part, replace it in accordance with the Instruction Manual. If there are no instructions in the Manual, please contact the sales agent through which you have purchased your tool or an authorized dealer near you for repair.
Likewise, if a switch failure occurs, contact sales agent through which you have purchased your tool or an authorized dealer near you for repair.
Do not use the tool if it does not start or stop with the start/stop switch.
- **Securely mount file.**
An improperly mounted file may fly out, causing possible damage to the tool or injury to the operator.
- **Always remove spanner, wrench, etc., once adjustment has been made with them.**
- **Use a tool appropriate for the application.**
Avoid heavy-duty application that is beyond the capacity of tool.
- **Do not use the tool for purposes other than what it is designed for.**
- **Do not abuse tool.**
Use tool in accordance with the specifications: you'll get the most out of it while ensuring safety.
- **Securely fasten workpiece in place.**
Use a vice or clamp to securely fasten the workpiece in place. It is much safer this way than holding it in your hand, allowing you to operate the tool with both hands.

ABOUT HANDLING

- **How to store tool.**
When the tool is not used, store it in a dry area and out of reach of children.
- **How to carry tool.**
Do not touch the start switch while the tool is being carried.
- **Do not leave the tool unattended while it is running.**
Turn off the start switch and disconnect the tool from power source. Do not leave the work area until the tool comes to a complete stop.

MAINTENANCE/SERVICE

- **Do not take apart or modify tool.**
Disassembly or modification carried out without the supervision of a qualified or authorized service engineer could result in an accident or injury.
- **Inspect cutting tool and accessories, etc.**
Always check to see that cutting tool and accessories, etc. are in good operating condition without damage or deterioration before you mount them on the tool. Should you find any damage to an accessory or part, please contact sales agent through which you have purchased your tool or an authorized dealer near you for repair.
- **Check parts for damage.**
When you have found damage to accessory or other part, carefully check the damaged part to determine the extent of influence it has upon the functions of the tool – that is, determine whether it can still perform its normal functions.
Check to see that moving parts are securely mounted is OK, that all parts are OK without damage, that they are properly mounted, and that the tool functions normally. Should you find any damage to an accessory or part that may hamper proper functioning of the tool, please contact sales agent through which you have purchased your tool or an authorized dealer near you for repair.
- **Have your tool repaired at an authorized Nitto Service Center.**
For repair or parts replacement, please contact the sales agent through which you have purchased your tool or an authorized dealer near you.
- **Use only Nitto genuine parts.**
Use of improper parts may result in serious an unexpected accident.
To obtain a Nitto genuine part, consult this Manual or contact the sales agent from which you have purchased your tool directly.
- **Do not detach label or nameplate from tool.**
When a label/nameplate gets damaged, worn or becomes missing, contact the sales agent through which you have purchased your tool or Nitto Kohki Co., Ltd. directly for a replacement.

DISPOSAL

- When a tool is taken permanently out of service, it is advised that the tool is disassembled, degreased and parts separated by material and recycled locally in the appropriate manner.

GENERAL:

PNEUMATIC TOOLS

WARNING

- **Use appropriate air pressure.**
Excessively high air pressure will increase the number of revolutions or strokes causing not only potential premature failure/breakage but could also lead to an unexpected accident or injury.
- **Connect tool to air supply line.**
There are various types of pipes running in a factory in addition to the pneumatic line (such as oxygen, nitrogen, gas and water). For this reason, always ensure that you are connecting to the pneumatic line.
- **Start tool properly.**
Turn the start switch OFF before connecting to the air supply line.
- **Always disconnect the tool from the air supply line before putting on/taking off any accessory and prior to carrying out any maintenance work.**
- **Avoid exposure to exhaust air.**
Pneumatic tool exhaust air contains oil and contaminated moisture. Make sure the exhaust air is not directed towards your face or anyone else within the work area.
- **Keep tool off electricity.**
This pneumatic tool is not electrically insulated. To avoid a potential electric shock do not use where there is a possibility of coming into contact with live electricity.

CAUTION

- **Handle tool carefully.**
Abusive use of tool could invite failure or accident.
Do not throw, drop or shock the tool.
- **Handle connecting hose carefully.**
Do not carry the tool by the air hose.
Do not pull the air hose to disconnect.

INSTRUCTIONS FOR THIS TOOL

About Your Tool

WARNING

- **Proper use.**

Always use the Abrasive Paper at a proper angle (15° to 30°) to the process surface. Do not operate other than on the surface used.

Negligence to do so causes the paper to be blown off or damaged, which in turn may result in serious accidents.

The Abrasive Paper must be of the same size as the pad. (e.g.: The Abrasive Paper 1" must correspond with the 1" pad.) If an incorrect-size Paper is used, the paper may be detached, causing serious accidents.

The chuck must have a diameter of 6mm. Do not use chucks not in conformity with the axis diameter of the pad to be used. Detachment of the chuck may result in serious accidents.

- **Use Nitto Kohki's Back-up Pad only.**

- **Checking before attaching Abrasive Paper.**

Never use any Abrasive Paper for which the allowable rotation speed shown on the Abrasive Paper is lower than the free speed of the MLS-20. Small rotation speed of the Abrasive Paper causes damage, which in turn may result in serious accidents.

Check for tears or chips on Abrasive Paper or pads; defective ones must not be used. NO Abrasive Paper soaked in liquid such as water must be used. A defective Abrasive Paper causes damage, which in turn may result in serious accidents.

- **Checking after attaching Abrasive Paper.**

After attaching a new Abrasive Paper, place the unit under an iron workbench to run it at least for one minute. Make sure that there is nobody around the rotation surface of the Paper. The test run usually reveals defects on the Paper, improper attachment, and incorrect dimensions or rotation speed.

- **Checking the rotation speed.**

Make sure that the air pressure is set at 0.6MPa at the start and that the free speed does not exceed the rotation speed specified on the unit label or in the instruction manual. If the rotation speed exceeds the limit, request check

- **For Abrasive Paper only**

Only Abrasive Paper must be used for the MLS-20. Grinding wheels must never be used for the unit.

1. USAGE

This tool is a handheld air sander that grinds steels with an Abrasive Paper

2. CHECK THE CONTENTS OF THE PACKAGE

Check the contents and make sure that the tool does not have any damage which may have occurred during transportation. The contents should correspond to the list as follows. In case of damage/missing parts, please contact the sales agent from whom you purchased the tool.

Part No.	Description	Qty
TP00475	Single Ended Spanner 14	2
TQ14382	PAD 2"	1
TQ14383	PAD 1.5"	1
TQ14384	PAD 1"	1
TQ14358	Abrasive Paper 1" x #60	2
TQ14359	Abrasive Paper 1" x #80	2
TQ14360	Abrasive Paper 1" x #100	2
TQ14361	Abrasive Paper 1" x #120	2
TQ14366	Abrasive Paper 1.5" x #60	2
TQ14367	Abrasive Paper 1.5" x #80	2
TQ14368	Abrasive Paper 1.5" x #100	2
TQ14369	Abrasive Paper 1.5" x #120	2
TQ14374	Abrasive Paper 2" x #60	2
TQ14375	Abrasive Paper 2" x #80	2
TQ14376	Abrasive Paper 2" x #100	2
TQ14377	Abrasive Paper 2" x #120	2
TQ14354	Instruction Manual	1

3. PART NAME

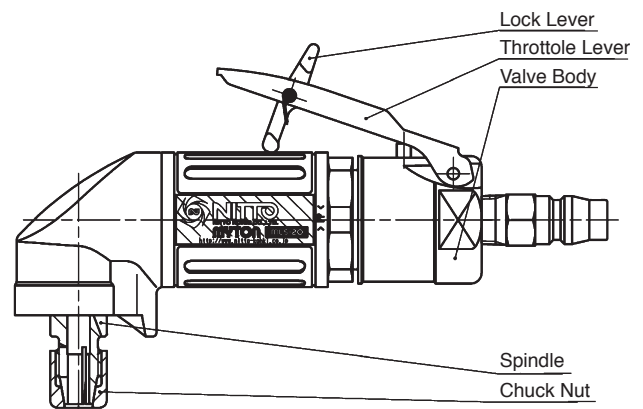

Fig.1

4. AIR SUPPLY

⚠ CAUTION

- Draw off drain before starting operation. If the drain enters into the tool, it can freeze around the exhaust port of the tool and result in output power reduction.

4-1. Air Pressure

Adjust air pressure to 0.6MPa (or 6 kgf/cm²) with the air regulator. Lower pressure may result in insufficient performance. Higher pressure may result in premature worn out of parts. It is important to maintain the proper pressure with pressure regulator on air line.

4-2. Air Line (Fig.2)

Use a 9.5 mm (3/8") I.D. air hose between the compressor and the tool. Compressed air comes to be cooled down and its drain be separated, as soon as the air leaves the compressor. The drain, however, is condensed in the piping, and can enter into the tool mechanism, and may cause malfunction. So, install an air filter and an oiler between the compressor and the tool.

4-3. oiler

Install an oiler between the compressor and the tool. Use machine oil ISO VG-10 for lubrication and rust prevention. Negligence of the oil supply may cause damages on the tool. Lubricating the tool with high viscosity oil reduces the tool performance.

4-4. Lubrication (Fig.2)

Before starting the tool, disconnect air hose from the tool and supply a few drops of machine oil ISO VG-10 to the air inlet port of the tool. Then reconnect and make idle running for a few seconds so that the oil should reach every part in the tool.

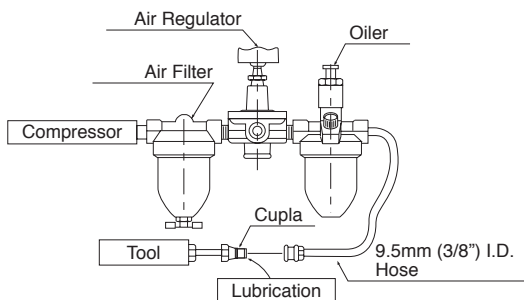

Fig. 2

5. OPERATION

⚠ WARNING

- Be sure to wear eye protection during operation. Use a dust mask if operation is exposed to dust.
- Always turn off the air supply and disconnect the air supply hose beforehand whenever replacing the Back-up Pad and/or Abrasive Papers.
- Never touch any moving parts of the tool when running.

5-1. MOUNTING AND REMOVING THE PAD AND ABRASIVE PAPER

(1) Pad

Removing

To loosen the pad, fix the Spindle with a Spanner 14 and then turn the Chuck Nut counterclockwise with another Spanner 14.

Mounting

To attach the Pad, push its axis all the way into the Spindle, fix the Spindle with a Spanner 14, turn the Chuck Nut clockwise with another Spanner 14, and then tighten it securely.

(2) Abrasive Paper

Removing

To detach the Abrasive Paper, take a grip on its edge, turn it counterclockwise.

Mounting

Align the center of the Abrasive Paper with that of the Pad. Turn the Paper clockwise to lock it.

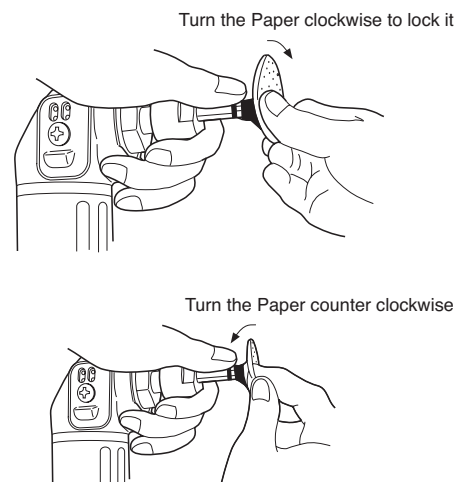

Fig. 3

5-2. Start and Stop

To start, release the lock lever and grasp the throttle lever.

To stop, release the throttle lever.

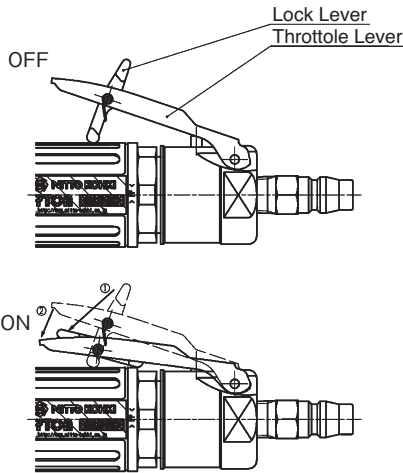

Fig. 4

5-3. Adjust Valve

WARNING

Be sure to keep hands clear of moving parts.

The desired number of rotation between maximum rpm and minimum rpm is obtained by turning the groove of valve clockwise or counterclockwise with screwdriver.

Maximum rotation

Position the groove of Adjust Valve horizontal to main body.

Minimum rotation

Position the groove of Adjust Valve vertical to main body.

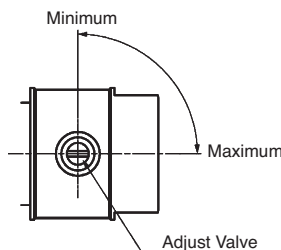

Fig. 5

5-4. GRINDS STEELS

WARNING

- Please do not pressed by a strong force to the object to be ground and Abrasive Paper. It may cause the pad and Abrasive Paper and damage of each part may be damaged.

The Hold the body, Move the switch to the ON position.

You work and pressed lightly on the object to be ground Abrasive Paper. Work efficiency does not improve even if pressed strongly.

6. STORAGE

CAUTION

When tool is not used, store it out of reach of children.

6-1. STORAGE

Avoid storing the tool in a location subject to high humidity. If the tool is left as it is used, residual moisture on the inside can cause rusting. Before storing, and after operation, oil the tool at the air inlet with machine oil ISO VG-10 and run it for a short time.

7. MAINTENANCE

7-1. MAINTENANCE

Supply additional appropriate amount of SUMICO Sumitec 305 Grease into the Gear Case with about once a month interval.

1. Loosen the Screw 4x12 and remove the Exhaust Cover, the Toothed Washer CW-4, the Spacer, the Exhaust Plate, and the Packing Cover.
2. Inject grease with a grease gun into the Grease Port next to the Exhaust Port. The outside diameter of the nozzle tip of the grease gun must be 3mm or smaller. The nozzle for grease nipple cannot be used for this grease filling, because the shape of the Grease Port is different from that of the nozzle for grease nipple.
3. Before putting back the Exhaust Cover, execute idle running and wipe out excessive grease.
4. For assembly, put back the parts in the reverse order of disassembly.

8. ORDERING SERVICE PARTS

- For further operational and handling information or for replacement of parts and components, contact the company from whom you purchased the tool or an authorized dealer.
- In ordering parts and components give each part number, part name and quantity required.
- Use only NITTO genuine parts.

9. OPTIONAL PARTS

A variety of Abrasive Papers are available for the MLS-20 so that you can use them according to the application.

compressor. The drain, however, is condensed in the piping, and can enter into the tool mechanism, and may cause trouble. So, install an air filter, an air regulator and an oiler between the compressor and the tool.

Part No.	Description(Qty)
TB09736	Abrasive Paper 1" x #40 Ass'y (25pcs)
TB09737	Abrasive Paper 1" x #60 Ass'y (25pcs)
TB09738	Abrasive Paper 1" x #80 Ass'y (25pcs)
TB09739	Abrasive Paper 1" x #100 Ass'y (25pcs)
TB09740	Abrasive Paper 1" x #120 Ass'y (25pcs)
TB09741	Abrasive Paper 1" x #180 Ass'y (25pcs)
TB09742	Abrasive Paper 1" x #240 Ass'y (25pcs)
TB09743	Abrasive Paper 1" x #320 Ass'y (25pcs)
TB09744	Abrasive Paper 1.5" x #40 Ass'y (25pcs)
TB09745	Abrasive Paper 1.5" x #60 Ass'y (25pcs)
TB09746	Abrasive Paper 1.5" x #80 Ass'y (25pcs)
TB09747	Abrasive Paper 1.5" x #100 Ass'y (25pcs)
TB09748	Abrasive Paper 1.5" x #120 Ass'y (25pcs)
TB09749	Abrasive Paper 1.5" x #180 Ass'y (25pcs)
TB09750	Abrasive Paper 1.5" x #240 Ass'y (25pcs)
TB09751	Abrasive Paper 1.5" x #320 Ass'y (25pcs)
TB09752	Abrasive Paper 2" x #40 Ass'y (25pcs)
TB09753	Abrasive Paper 2" x #60 Ass'y (25pcs)
TB09754	Abrasive Paper 2" x #80 Ass'y (25pcs)
TB09755	Abrasive Paper 2" x #100 Ass'y (25pcs)
TB09756	Abrasive Paper 2" x #120 Ass'y (25pcs)
TB09757	Abrasive Paper 2" x #180 Ass'y (25pcs)
TB09758	Abrasive Paper 2" x #240 Ass'y (25pcs)
TB09759	Abrasive Paper 2" x #320 Ass'y (25pcs)
TQ14382	PAD 2"
TQ14383	PAD 1.5"
TQ14384	PAD 1"